

Code: 57 62060100002

2.07

# BWM150 LOMBARDINI 6LD400

SELF-PRIMING DIAPHRAGM PUMP

## Product description

Self-priming diaphragm pump is all-purpose especially designed for 24 hour a day operation. It requires neither foot valves nor previous filling with water. It is capable of pumping any type of liquid, even if it contains large diameter solids, slimes, etc. The pump can run dry. The pump is on trailer with rubber wheels.

### Overall dimensions (mt)

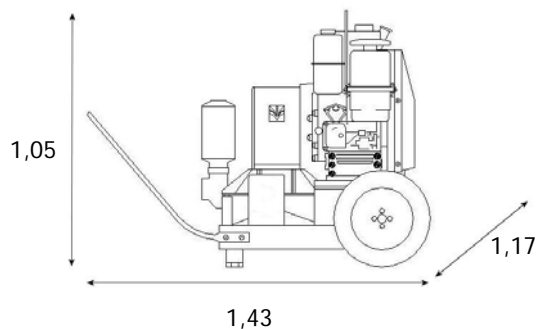

### Materials used

All parts: aluminium  
 Membrane and valves: neoprene  
 Reduction gear: hardened steel

### Performance curve

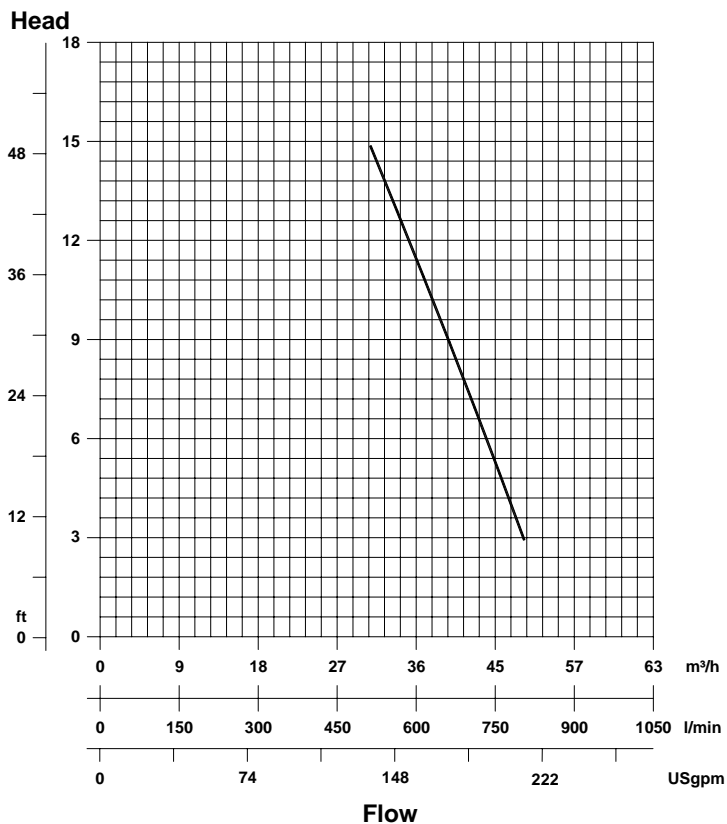

### Technical Data

Solids throughlet	60 mm
Suction diameter	150 mm
Discharge diameter	150 mm
Motor displacement	395 cm <sup>3</sup>
Rated power	5,0 kW
Cylinders no	1
Nominal speed	3000 r.p.m.
Consumption	1,7 l/h
Weight	345 kg
Supply	Diesel oil
Motor cooling	Air
Liquid temperature	max 70 °C
Liquid density	max 1.100 kg/m <sup>3</sup>
pH of pumped liquid	5,5 ÷ 9,0
Fuel tank	4,3 lt.
Starting by rewind starter	
Options: Coupling joints, Dewatering accessories	

The pump unit shall not be used in explosive or flammable environments.  
 The maker reserves to itself the right to make changes without notice.

*Engineered for life*