

Code: 57 62030100014

2.07

**BWM 75**
**LOMBARDINI 15LD225**

SELF-PRIMING DIAPHRAGM PUMP

**Product description**

Self-priming diaphragm pump is all-purpose especially designed for 24 hour a day operation. It require neither foot valves nor previous filling with water. It is capable of pumping any type of liquid, even if it contains large diameter solids, slimes, etc. The pump can run dry. The pump is on trailer with rubber wheels.

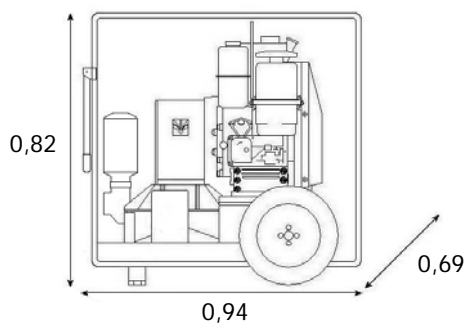
**Overall Dimensions (mt)**

**Materials used**

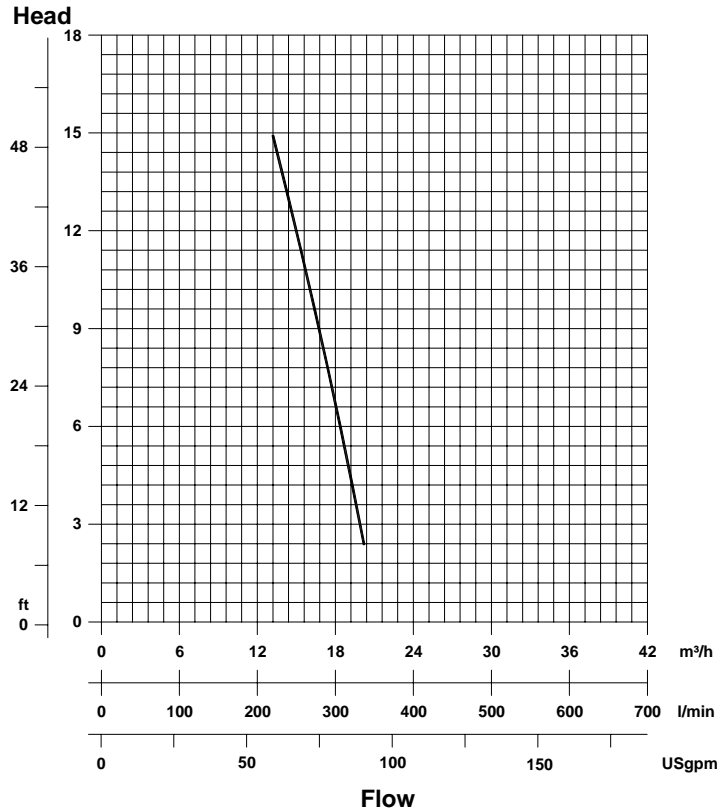
All parts: aluminium  
 Membrane and valves: neoprene  
 Reduction gear: hardened steel

**Performance Curve**

**Technical Data**

Solids throughlet	50 mm
Suction diameter	80 mm
Discharge diameter	80 mm
Motor displacement	224 cm <sup>3</sup>
Rated power	2,8 kW
Cylinders no	1
Nominal speed	3000 r.p.m.
Consumption	0,9 l/h
Weight	96 kg
Supply	Diesel oil
Motor cooling	Air
Liquid temperature	max 70 °C
Liquid density	max 1.100 kg/m <sup>3</sup>
pH of pumped liquid	5,5 ÷ 9,0
Fuel tank	3,0 lt.
Starting by rewind starter	
Options: Coupling joints, Dewatering accessories	

The pump unit shall not be used in explosive or flammable environments.  
 The maker reserves to itself the right to make changes without notice.

*Engineered for life*